

SME

SERIES III Precision Pick-up Arm

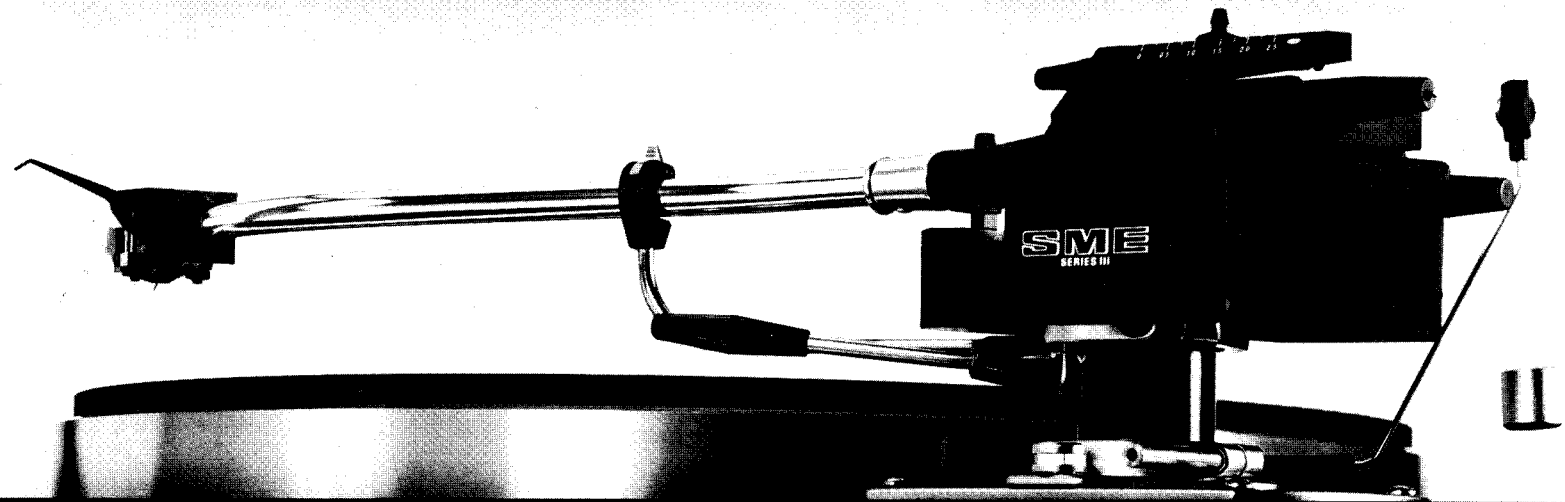

INSTRUCTION BOOK

Introduction

This booklet has received the same attention to detail in its preparation as the Series III precision pick-up arm. Please read it carefully before attempting its installation and use. Time spent in this way will be rewarded in realising the performance capabilities of this unique product.

The Company's policy is the continuous improvement of its products. We therefore reserve the right of departure from illustration or specification that this might occasion.

Contents

Page	
2	Introduction
4	Contents of the pack
5	Dimensions
6	Assembling the arm
7	Layout
8	Fitting the arm
9	The audio lead
10–11	Fitting the cartridge
12–13	The balance system
14	Fitting the damper
15	Longitudinal balance and tracking force
16	Height adjustment
17	Lateral balance
18	Cartridge azimuth
19	Tracking adjustment
20	Filling the damper
21	Bias adjustment
22	Operation
23	Appendix

Contents of the pack

The pack is the only one in which your Series III precision pick-up arm can be safely transported. Please keep it for possible future use. It contains the following:-

- 1—Main assembly
- 1—Carrying arm CA-1
- 1—Damper tank and rim (assembled together)
- 1—Flask of FD.200 damper fluid
- 1—Each paddles for damper 13 mm. wide (white), 9 mm. wide (grey), 7 mm wide (black)
- 1—Paddle retaining screw
- 1— $\frac{5}{16}$ " (8 mm.) balance weight (assembled)
- 5— $\frac{1}{16}$ " (1.6 mm.) balance weights (3 assembled, 2 separate)
- 5—Weight spacers $\frac{1}{16}$ " (1.6 mm.) (2 assembled, 3 separate)
- 1—Bias weight and filament
- 1—Bias guide
- 1—Sets cartridge fixing screws, nuts and spacers
- ~~1—Sachet of cartridge coating compound~~
- 1—Lateral balance support
- 1—Audio lead
- 1—Tracking adjustment spanner
- 1—Azimuth gauge
- 1—Hexagon wrench
- 1—Set of 4 woodscrews
- 1—Instruction manual
- 1—Mounting template
- 1—Alignment protractor
- 1—Guarantee registration card

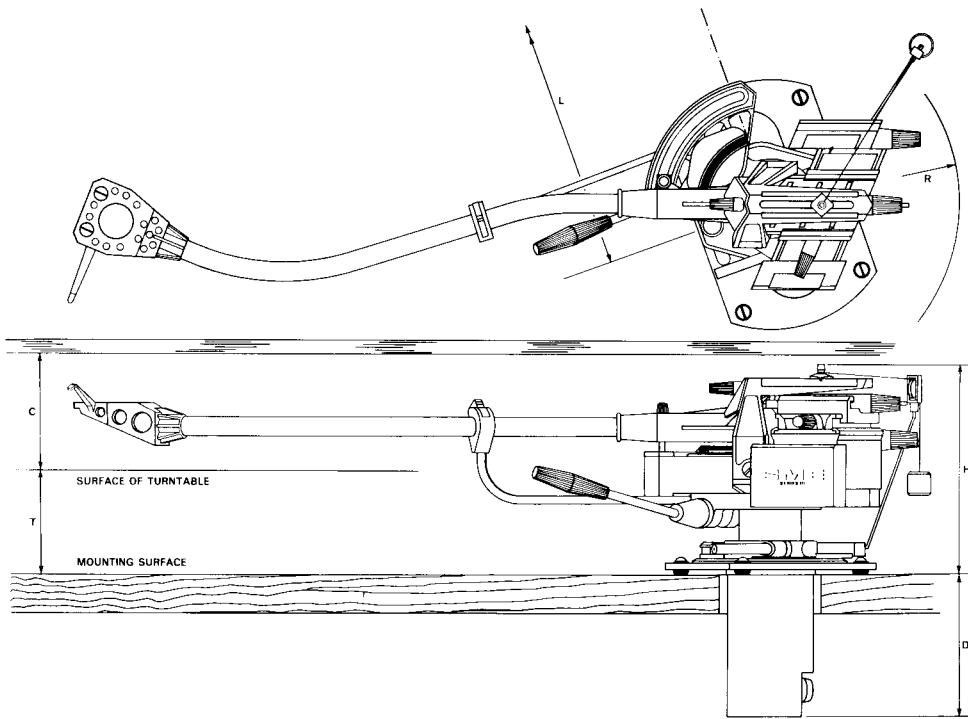

Dimensions

	Inches	mm.
Nominal length, pivot to stylus	9	229.0
Distance from bedplate centre to turntable centre (L)	8.48	215.4
Tracking adjustment	$\pm \frac{1}{2}$	± 12.7

Height above mounting surface (H)—adjustable

max.	$3 \frac{1}{4}$	82.6
min.	$2 \frac{3}{8}$	60.3

Height of turntable surface above mounting surface (T)

max.	$1 \frac{5}{8}$	41.3
min.	1	25.4

Note When the turntable surface is more than $1 \frac{5}{8}$ " (41.3 mm.) above the surface on which the arm is mounted, a spacer, SME accessory P1, is required.

Depth required below mounting surface (D)	$1 \frac{7}{8}$	47.6
Clearance required for balance weights (R)	$2 \frac{1}{2}$	63.5
Clearance required between turntable surface and cabinet lid (C)	$1 \frac{3}{4}$	44.5

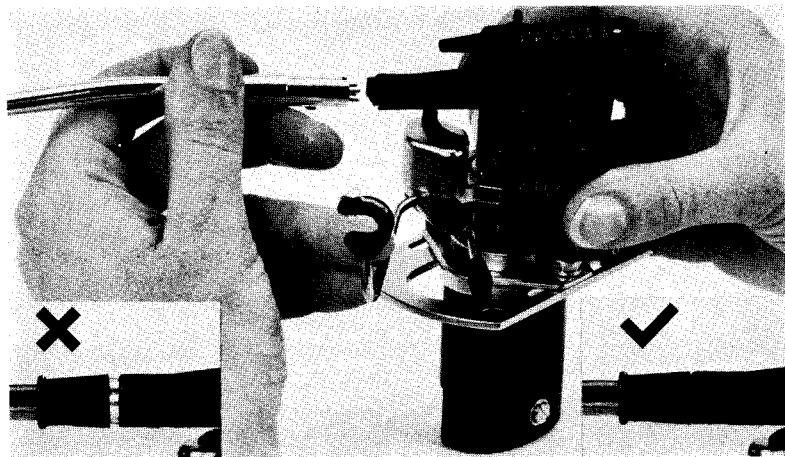

301

Assembling the arm

301 Insert the carrying arm into the bearing carrier and push firmly home.

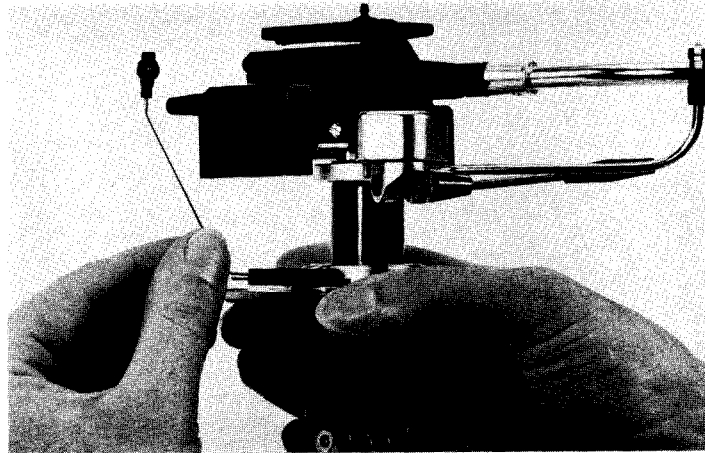

302

302 Insert the bias guide into its housing and push firmly home.

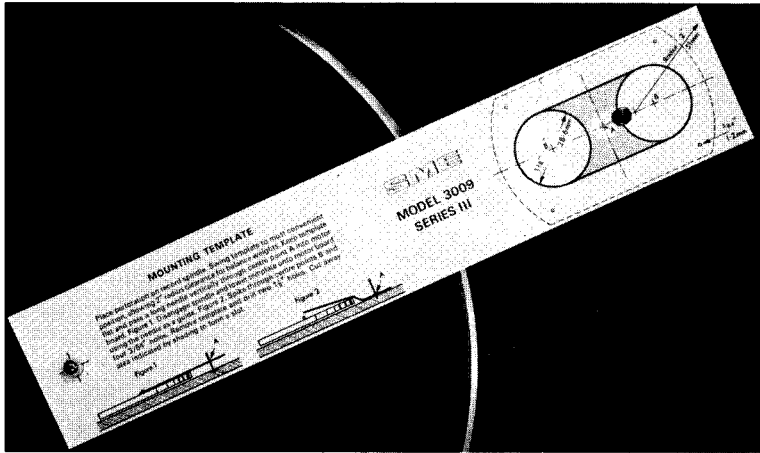

303

Layout

Some turntables are prepared to receive SME arms. When a motorboard or pick-up mounting board must be cut, proceed as follows:

- 303 Establish the position for the bedplate with the mounting template in accordance with the instructions printed on it.



304

- 304 Normally the arm will be installed so that the centre line of the bedplate is radial with the turntable. When this is not possible it may be turned into another position. This reduces the effective range of tracking adjustment available but is not detrimental provided it is placed so that the requirements of the alignment protractor can be satisfied. A departure of 70° is probably the maximum that will allow this.



305

Fitting the arm

305 Drill and form a cut-out in accordance with the template. Ensure that it is large enough to clear the screening can completely. Drill the four $\frac{3}{64}$ " (1.2 mm.) pilot holes for the woodscrews.

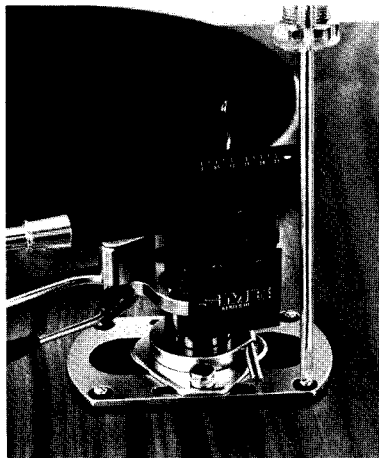

306

306 Insert the four woodscrews through the grommets in the bedplate and screw partly home. As delivered the arm is adjusted to suit its pack. It may therefore be necessary to refer to Page 16 paragraphs 336 and 337 at this point and readjust it to clear the turntable.

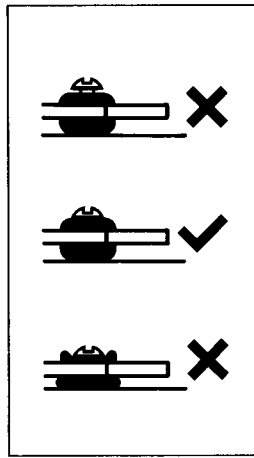

307

307 Adjust the screws as shown.

Alternatively, as some people prefer, the bedplate grommets can be removed. It would then be necessary to place a small washer under the head of each woodscrew or use a slightly larger gauge of screw.

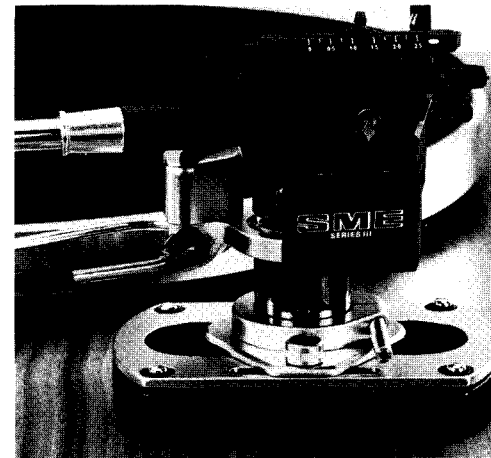

308

308 When the surface of the turntable is more than $1\frac{5}{8}$ " (41 mm.) above that on which the bedplate is mounted, a spacer SME accessory P1 is required. It is complete with woodscrews. Nuts and bolts are available on request for fixing to metal decks.

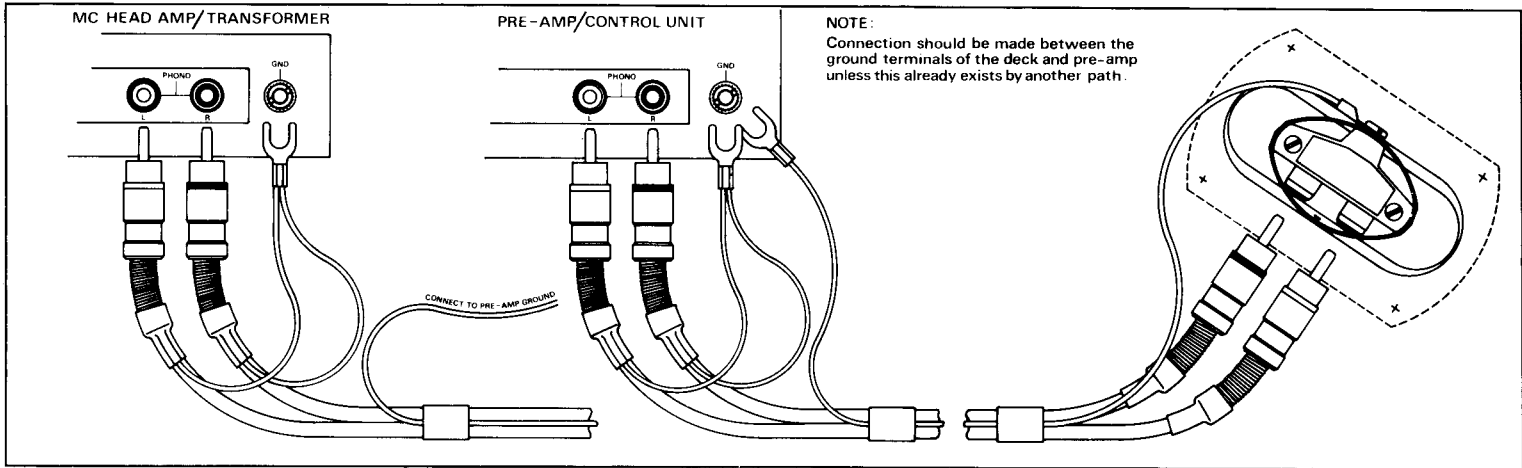

New LCOFC audio lead (modification)

The illustration shows use with and without a mc head amp/transformer and phono plug connections should be made accordingly.

Connect the ground lead serving the arm to the pre-amp ground, and those from the rear of the phono plugs to the ground terminal on the piece of equipment to which these plugs are connected.

If the turntable has a ground terminal, it too should be connected to the pre-amp ground, provided it is not already grounded by another path.

The system has been designed for a high S/N ratio and if this is not achieved multiple ground paths or the over proximity of mains equipment will be likely causes. Some cartridges have an external foil tag connecting the right channel ground terminal to the cartridge body. For use in a metal shell it will be necessary to remove this with a small pair of tweezers or the point of a blade, lifting the tag off over the terminal pin. If this is not done a ground loop may be formed, causing hum on the right channel.



313

Fitting the cartridge

For convenience the carrying arm should be removed – see 301 page 6.

313 Place a small piece of cartridge seating compound inside the shell between the cartridge mounting holes.

314 Fit the pin jacks to the cartridge terminals using a small pair of fine nosed pliers. If you don't have a pair, buy them – they will be a good investment for work on your system generally and otherwise you will almost certainly damage the pin jacks. Connections are:- White to left channel: Red to right channel: Blue to left ground: Green to right ground. To accommodate variations in terminal diameter the jacks may have to be closed down with the pliers or opened up with a screwdriver blade as required. Connections to the cartridge terminals must never be made by soldering. The shell has been kept as

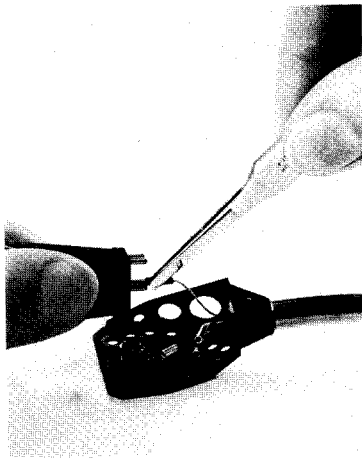

314



315

compact as possible. To accommodate some cartridges it may be necessary to bend the tags of the pin jacks outwards at a right angle so that they do not project beyond the ends of the terminal pins.

315 Select screws of appropriate length for the cartridge. Do not use spacers between the cartridge and shell unless the cartridge contours make it unavoidable.

316 Fit the nuts. Sometimes it is convenient to place spacers between the cartridge and the nuts or even to invert the screws, placing the nuts on top of the shell. Afterwards, any excess shank length can be removed with a pair of sharp scissors followed by a trim with a nail-file. This is important in some instances to prevent the screws touching the records.

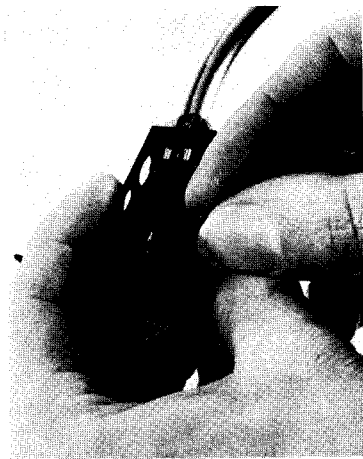

316

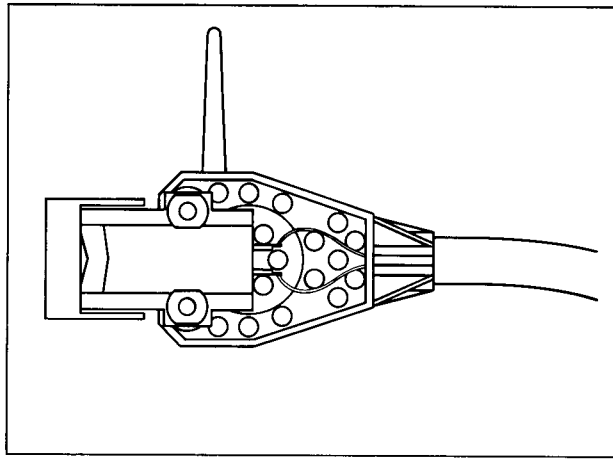

317

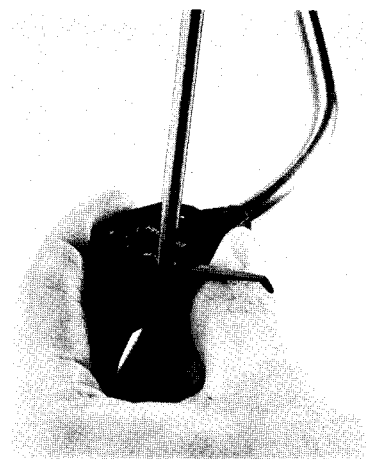

318

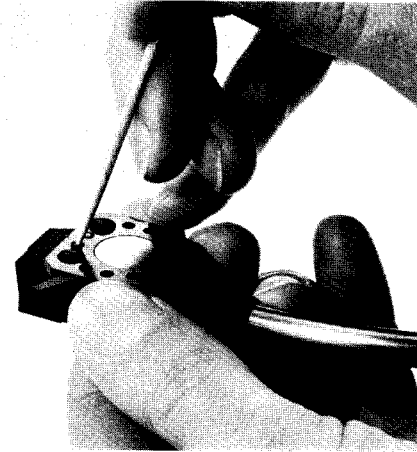

319

Fitting the cartridge (Cont'd)

317 Check that the cartridge lies symmetrically in the shell. This is important.

318 Press the cartridge body firmly against the shell to squeeze out excess compound and tighten the screws taking care to preserve the position of the cartridge. The seating compound ensures that the cartridge is kept in position without excessive tightening of the screws. Align the screw slots and nuts for a neat appearance.

319 Excess compound can be removed using a cocktail stick or something similar. Temporarily replace the carrying arm.

Cartridge seating compound use is discontinued, please disregard the instructions referring to it



320



321

The balance system

The main balance weight comprises laminations in lead and plastic which can be combined to suit a wide range of cartridges. The range assembled at the factory covers from 6 to 10½ grams. To change it proceed as follows:-

- 320 Unscrew the longitudinal balance adjustment until the thread disengages.
- 321 Slide the complete balance weight backwards drawing it off its guides.

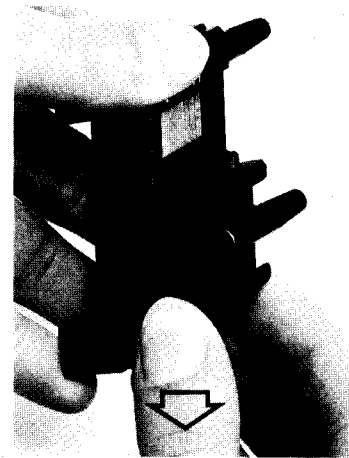

322

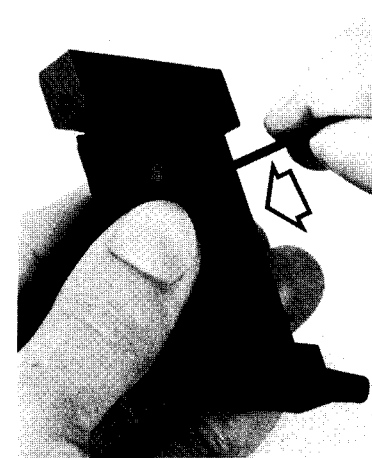

323

- 322 Press the lid of the weight housing in the direction indicated and remove it.
- 323 Invert the housing and remove the weights by pushing a suitable probe through the holes in its base.



324

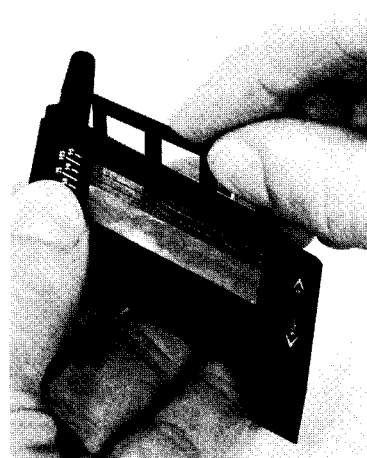

325

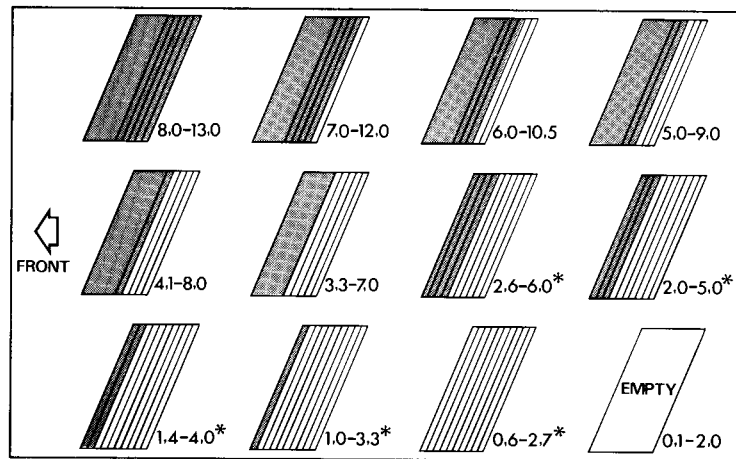

326

The balance system (Cont'd)

324 Re-pack the housing with weights to suit the cartridge in use.

325 Add spacers to fill the housing completely.
Refit the lid and replace the main balance weight.

326 Shows all the possible combinations of weights and spacers. The figures indicate in grams the range of cartridge weights that each will balance. To preserve low inertia the metal weights must always be at the front of the housing and the selected combination the heaviest that will balance the cartridge so that the balance weight will be as far forward as possible.

Arrangements marked with an asterisk require additional spacers. They are available as an accessory from SME.

WARNING: The weights are made of lead (Pb). Please keep them away from children.

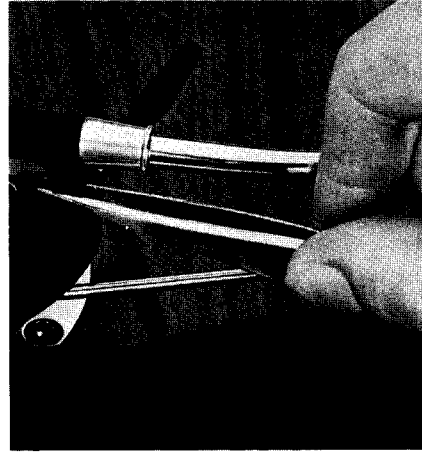
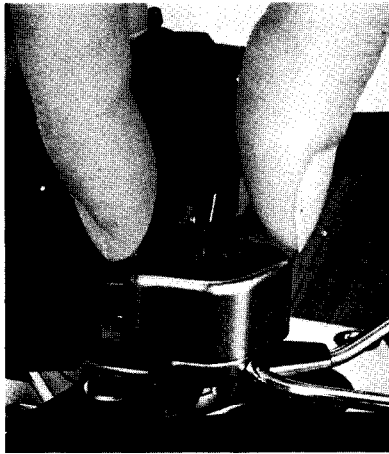

327

328

329

330

Fitting the damper

Use of the FD.200 damper is optional but it is recommended for all cartridges. To fit it proceed as follows:-

- 327 Remove the carrying arm. Raise the control lever and holding the lift between finger and thumb, pull it upwards out of the control.
- 328 Fit the tank over the dashpot jacket, pressing it down as far as it will go. Replace the lift and carrying arm.
Paddles of three widths are provided. Select the paddle to suit the compliance of the cartridge by reference to the literature which accompanied it. If different figures are given for vertical and lateral compliances, consider the higher figure. Our recommendation is as follows:-
 - 13 mm wide (White) for compliances below 10 cu.s.
 - 9 mm wide (Grey) for compliances above 10 and below 20 cu.s.
 - 7 mm wide (Black) for compliances above 20 cu.s.

Use low viscosity damping fluid Part No. 2013 (LV), available from SME, for cartridges having a compliance above 30 cu.s.

NOTE: 1 compliance unit (cu)= 1×10^{-6} cm. per dyne. If the compliance is not stated the black paddle can be safely used whilst information is obtained from the cartridge manufacturer.

- 329 Insert the paddle in the tank ensuring that the curvature of the two parts agree. Insert the squared end of the shank into the lug on the bearing carrier.
- 330 Secure the paddle using the paddle retaining screw. It will be found with a little practice that by bringing the lug over the paddle it can be drawn up into it with the screw without the need for tweezers.



331

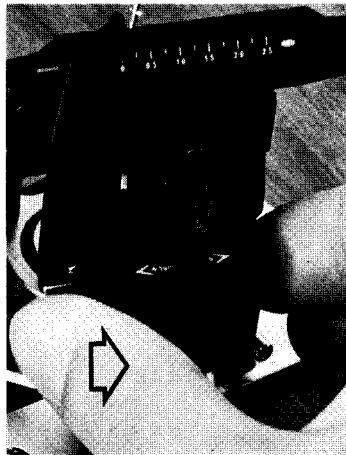

332

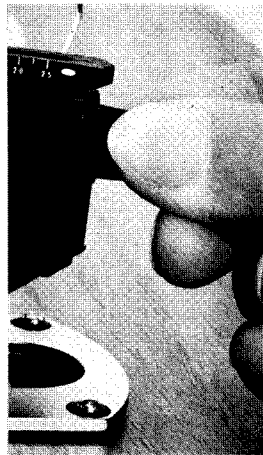

333



334



335

Longitudinal balance and tracking force

331 Set the fine adjustment of the rider weight to zero.

332 Push the coarse rider weight as far as it will go in the direction of the arrow marked O.

333 Turn the longitudinal balance adjustment until the arm balances in an approximately level position.

334 Set the required tracking force with the fine adjustment rider weight.

335 If a tracking force in excess of 1.5 grams is required, push the coarse rider weight as far as it will go in the direction of the arrow marked +1. This adds 1 gram to the tracking force indicated on the fine adjustment scale, increasing the total range to 2.5 grams.

NOTE: Use of the coarse rider weight as an adjunct to initial balancing is sometimes convenient. Changing its position before adjustment 333 does not change the values indicated on the rider weight scale. Changing its position after adjustment 333 will add or subtract up to a maximum of 1 gram. from the figure indicated by the rider weight scale.

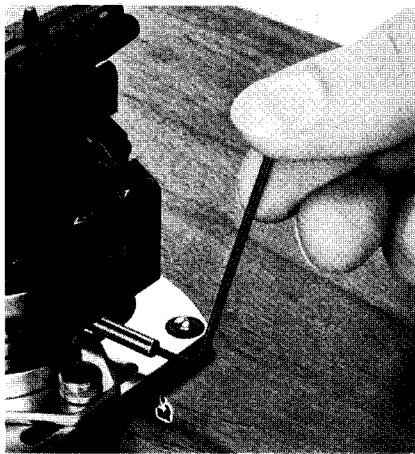

336

Height adjustment

336 Hold the main assembly just above the base, and release the base clamp with the other hand.

337 Rotate the pillar to position the arm-rest in a convenient position relative to the turntable. The headshell must not be more than 3" (76 mm.) and not less than 1" (25 mm.) from the edge of the turntable. At the same time raise or lower the pillar in the base so that the arm will be approximately parallel with the surface of the record when it is being played. Re-lock the pillar, view and re-adjust as necessary.

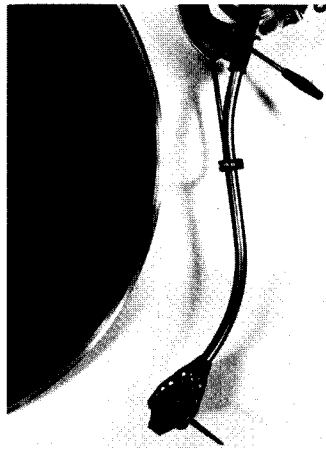

337

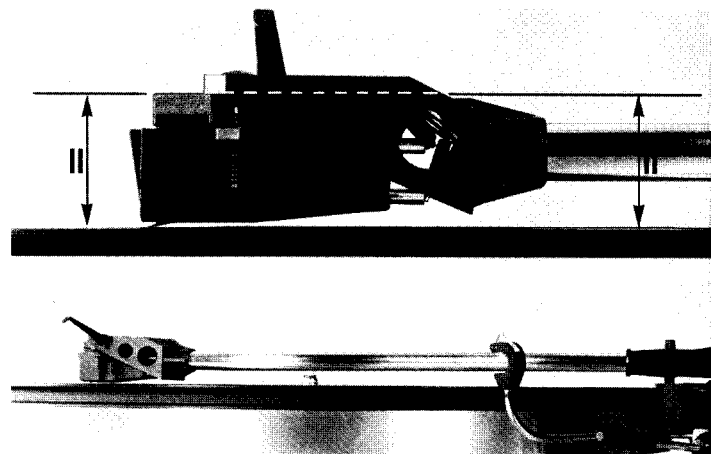

338

338 The horizontal datum is usually the top of the cartridge and if it has been correctly fitted it will be parallel with the top of the shell and consequently with the tone-arm. If it is not, a small piece cut from a visiting card inserted at the appropriate point between the cartridge and shell will generally put matters right. The raising and lowering control is adjusted at the factory to raise the stylus approximately .25" (6 mm.) above the surface of the record and this should be achieved if the arm has been correctly installed and adjusted.



339

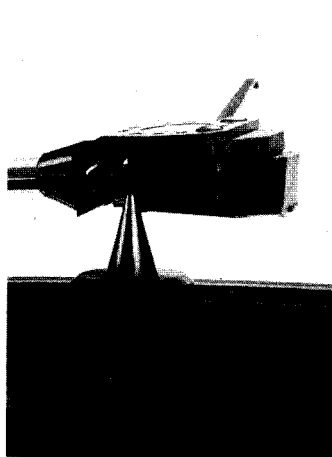

340

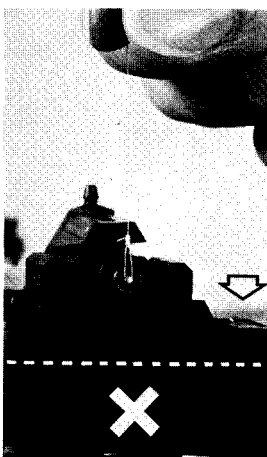

341



342



343

Lateral balance

339 Lateral balance is effected by adjusting the control on the side of the weight system.

340 Remove the protective paper from the base of the lateral balance support and attach it to an old record with the flat facing towards the cartridge. The headshell has a spigot about half way along its left hand edge as viewed from the front, insert it in the cup of the balance support.

Using a loop of thread such as the end of the bias filament lift the rear of the arm. The range of movement is not great but sufficient to indicate whether the arm lifts equally on both sides or on one side only.

341 The imbalance indicated would be corrected by counter-clockwise rotation of the control.

342 In this position the arm is laterally balanced.

343 The imbalance indicated would be corrected by clockwise rotation of the control.

NOTE: This adjustment is not critical, an approximate setting is all that is needed.

Replace the protective paper on the base of the lateral balance support.

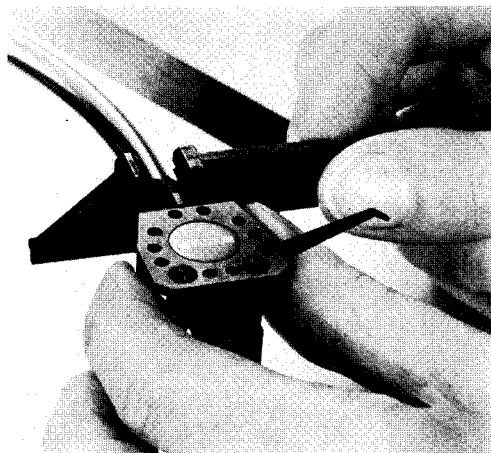

344

Cartridge azimuth

344 Fit the azimuth gauge to the back of the shell pushing it home so that the webs on the shell enter the slots on the gauge.

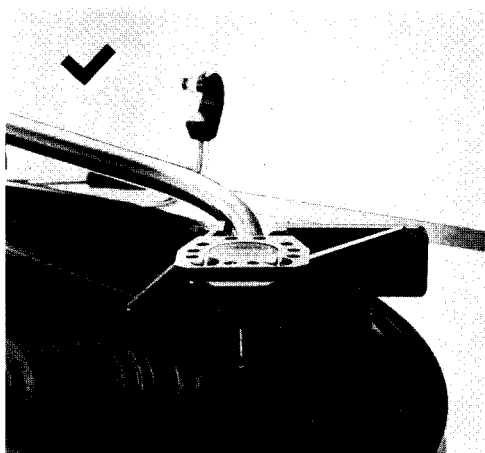

345

345 Rest the gauge on a record and check that its bottom edge is parallel with the surface.

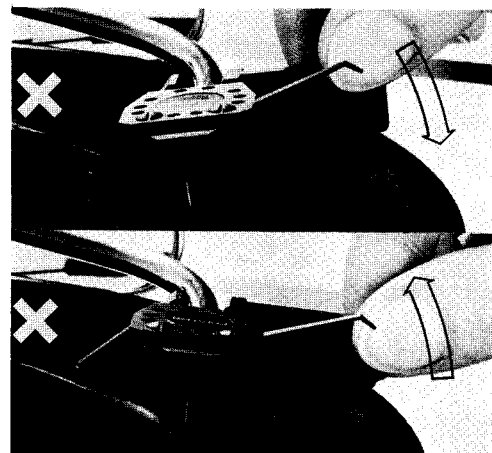

346

346 Corrections are made by twisting the shell on its carrying arm as indicated. The cartridge should be clear of the record and the carrying arm held in the other hand during this adjustment.

DESIGN CHANGE

The carrying arm CA-1 has been modified to provide a larger shell and geometry optimised for 12" records.

- 1 The original design. Arms of this type should be used in conjunction with the section headed 'Tracking Adjustment' on page 19 of the Series III and page 17 of the Series IIIS instruction books. The alignment protractor, with single null point at 2.375" (60 mm) radius illustrated therein, should also be used.
- 2 The modified design. This should be used with the alignment protractor with two null points, the inner at 2.60" (66 mm) and the outer at 4.76" (121 mm) radius, in accordance with the following instructions:-
- 3 Pierce the two holes in the protractor for the stylus. Place it on the turntable spindle. Position the base on the bedplate as far forward as it will go and insert the stylus in the inner pierced hole.
- 4 Move the base backwards until the cartridge and shell appear symmetrical with the lines on the protractor at the inner point.
- 5 Shows inaccuracy, similarly Fig. 3. The arrows indicate the direction of movement necessary to correct it.
- 6 Transfer the stylus to the outer pierced hole and adjust the arm until the conditions shown in Figs. 4 and 6 are both met.



1

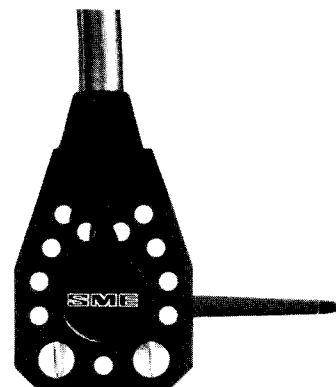

2

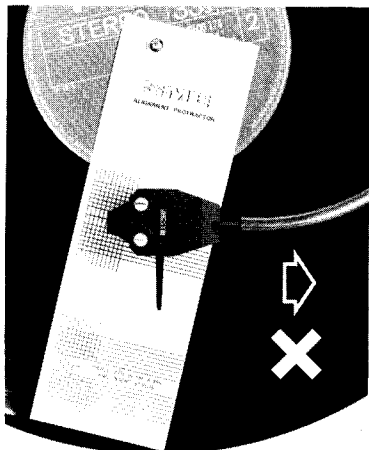

3



4

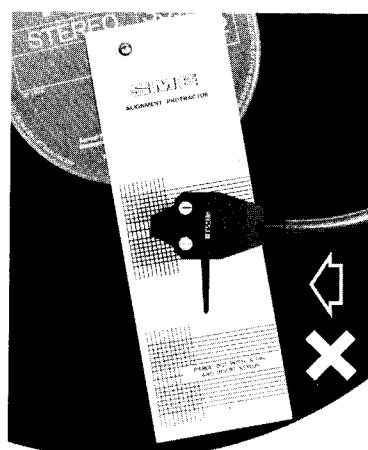

5

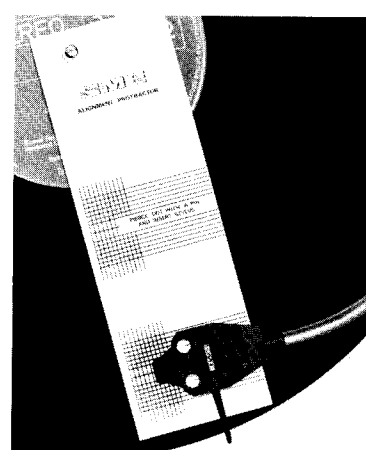

6

When using the modified carrying arm, CA-1, the weight range of cartridges that can be balanced, given on page 12 of the Series IIIS and page 13 of the Series III instruction books, is changed to the figures shown below:-

Series III

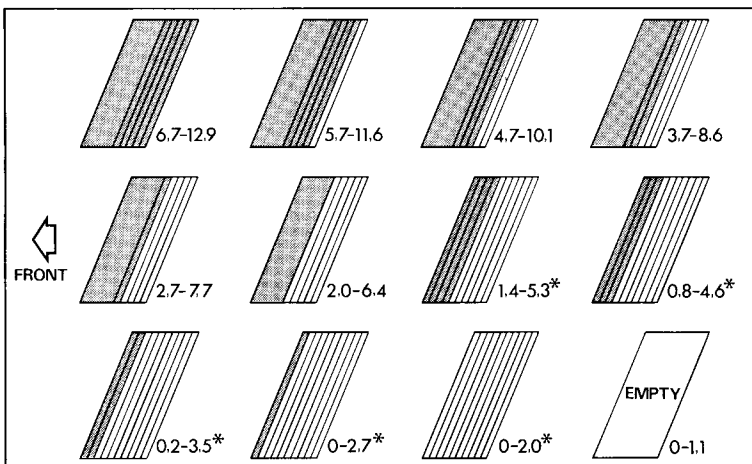

326A

Always use the heaviest combination of weights which will balance the cartridge.

WARNING: The weights are made of lead (Pb). Please keep them away from children.

Series IIIS

Number of weights	Weight range of cartridges that can be balanced. Grams.
Weights and clamp omitted	0 – 1.1
1 Weight with clamp	0 – 2.7
2 Weights with clamp	1.1 – 4.6
3 Weights with clamp	2.7 – 6.8
4 Weights with clamp	4.6 – 9.2
5 Weights with clamp	6.8 – 12.5

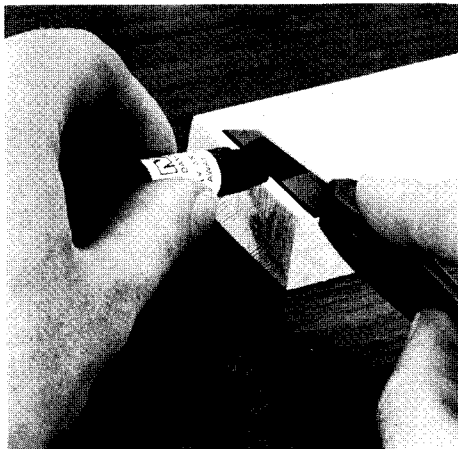

351



352

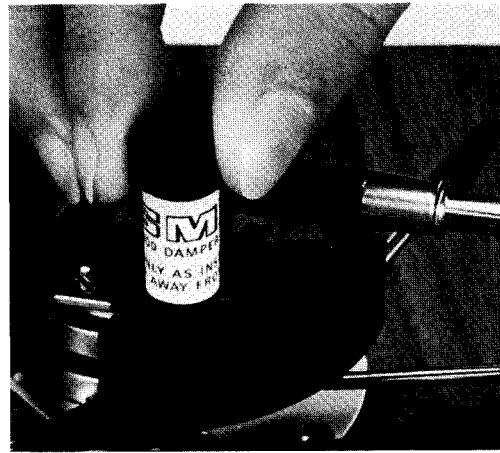

353

Filling the damper

If the damper has been fitted it should now be filled as follows:-

- 351 Slice off the end of the flask of damping fluid with a sharp trimming knife at the point indicated. The flask contains a metered amount sufficient to fill the tank to a depth of $\frac{1}{4}$ " (6 mm.).
- 352 Engage the flask in the top of the tank so that it stands upright as shown.
- 353 Unscrew the cap of the flask allowing the fluid to flow into the tank and settle. This will take about 10 minutes. Carefully remove the flask and put it safely away. Silicone fluid can cause irritation to the eyes and care should be taken to wash any surplus from the hands.

The recommended damping rates are a good compromise to maintain a substantially similar motion pattern of stylus and cartridge in the subsonic range, assuming records in normal condition and a realistic tracking force. The situation however has

number of variables, the degree of warp, the compliance of the particular cartridge etc. In certain cases a small degree of 'tuning' may be necessary for a particularly warped record. Tuning may be achieved in three ways:-

1. Remove some of the damping fluid a little at a time with a matchstick returning it to the flask for possible re-use. The bottom of the flask will need to be re-sealed and stored with the screw cap downwards.
2. Proceed as 1 above and reduce the viscosity of the remaining fluid by the addition of REDUCING FLUID, Part No. FD.2019, available from SME, in accordance with the instructions which accompany it.
3. Use a smaller paddle, unless the smallest paddle is already in use, in which case change to lower viscosity fluid, Part No. FD.2013 (LV) available from SME.

In practice it is only rarely that the standard provisions require alteration.

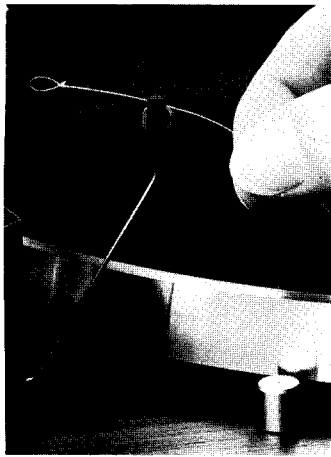

354

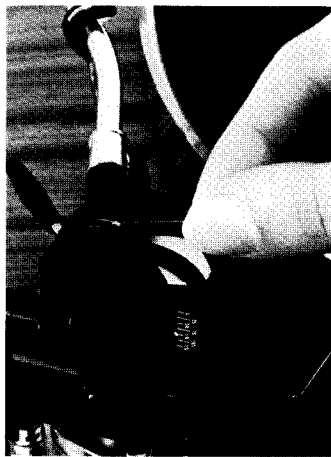

355

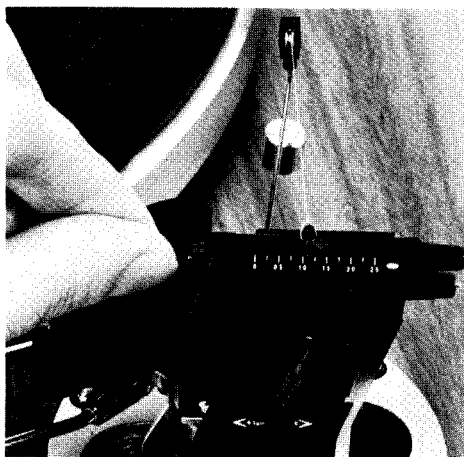

356

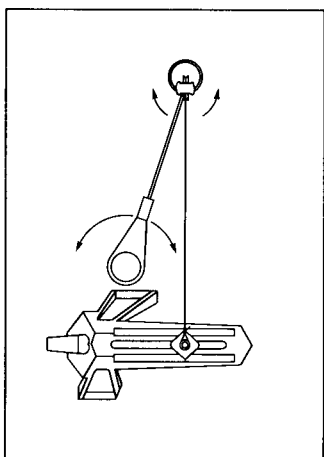

357

Bias adjustment

354 Thread the filament through the bias pulley housing.

355 Pass the loop over the stud in the top of the bias indicator.

356 Adjust the bias control so that the setting indicated on the scale corresponds to the tracking force in grams.

357 Position the bias guide so that the filament is at approximately 90° to the indicator slideway in the top of the bias housing when the stylus is over the outer groove of a 12 inch record. Rotate the guide pulley housing to align it with the filament and ensure that this is lying in the groove of the pulley.

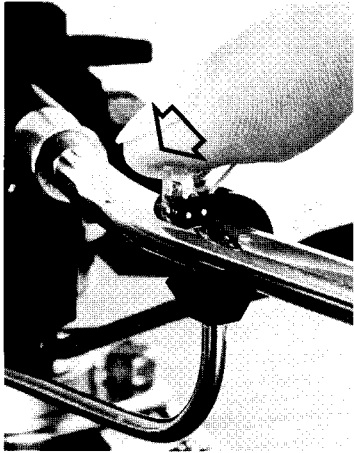

358

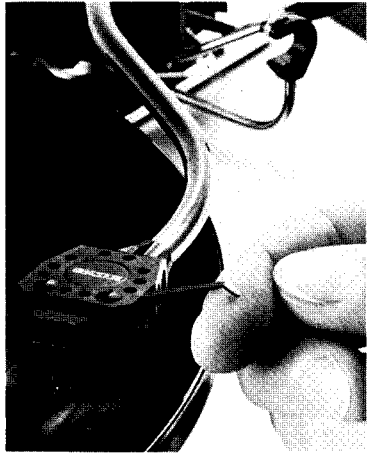

359

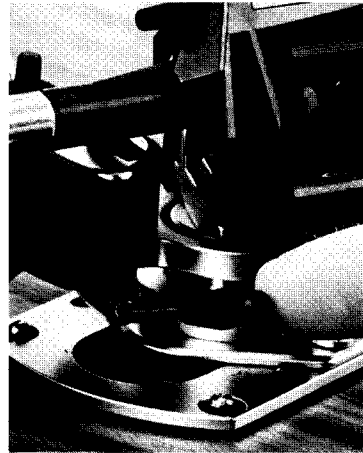

360



361

Operation

358 With the control lever raised release the carrying arm from its rest.

359 Place the stylus over the selected band on the record.

360 Move the control lever forward.

361 Allow it to fall freely.
After playing, raise the control lever to lift the stylus from the record and return the arm to its rest.

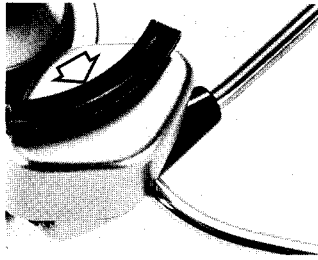

We hope these instructions have made installation of your SME Series III precision pick-up arm simple and straightforward. Care for it as you would a camera. Do not attempt to take it to pieces. Do not apply oil or other lubricants to any part of it.

If the arm drifts outward during lowering and raising it usually indicates the presence of contaminant on the rubber insert in the arm lift. To restore positive working proceed as follows:-

- a) Clean the rubber insert in the arm-lift with a petroleum based solvent used sparingly on a paper tissue.
- b) Rub the insert with an unused portion of the tissue so that it is quite dry.
- c) Clean the underside of the tone arm where it contacts the rubber insert in the same way.

If you have a problem concerning the operation or repair of your pick-up arm, write to the address overleaf. We provide quick and efficient service direct from the factory to any part of the world. In the first instance please write quoting model, type and serial number. Do not send the arm to us unless requested to do so.

SME

The best pick-up arm in the world

Manufactured in England by **SME LIMITED - STEYNING - SUSSEX - BN4 3GY**

 Steyning 0903 - 814321